

Table of Contents

Cover Page	1
General Specifications	4
Operating Precautions	5
Operation and Set-up	7
Operating Controls	8
Maintenance	10
Machine Adjustments	11
Wiring Diagram	13
Troubleshooting	15
Accessories	16
Replacement Parts	17

General Specifications

The Wilton 20 Inch Tradesman Variable Speed Drill presses Models 2221VS, 2223VS, 2232AC, and 2234AC are available in manual speed control or inverter speed control configuration. Electrical power options are single-phase, 115 and 220 volts, or 3-phase, 440 volts.

Specifications

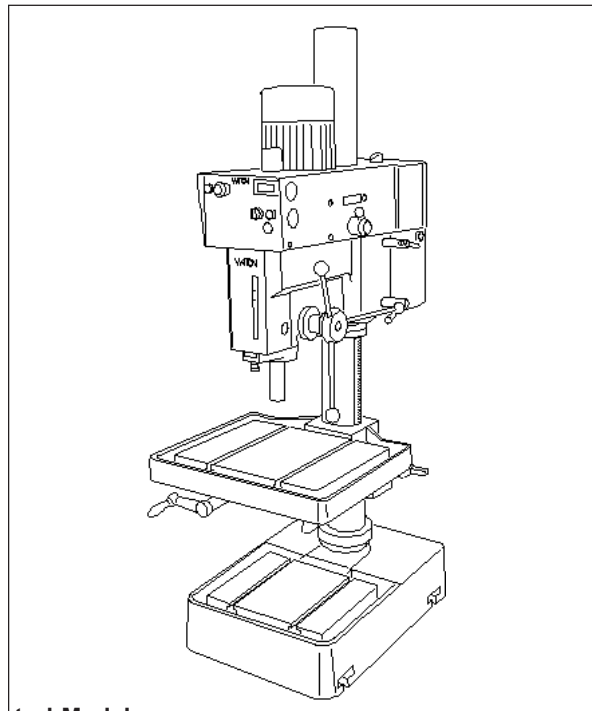

	<u>Manual Speed Control Models</u>		<u>Inverter Speed Control Models</u>	
	2221VS	2223VS	2232AC	2234AC
Drilling Capacity				
Cast Iron	1-1/4 In.	1-1/4 In.	1-1/2 In.	1-1/2 In.
Steel	1 In.	1 In.	1-3/8 In.	1-3/8 In.
Spindle to Table (Max.)	32-3/8 In.	32-3/8 In.	32-3/8 In.	32-3/8 In.
Spindle to Base (Max.)	44-1/2 In.	44-1/2 In.	44-1/2 In.	44-1/2 In.
Spindle to Column (Max.)	10-7/16 In.	10-7/16 In.	10-7/16 In.	10-7/16 In.
Motor				
Rating	2 hp, 1-Phase	2 hp, 3-Phase	2 hp, 3-Phase	2 hp, 3-Phase
Voltage	115/220 V	220/440V	220V	440V
Pre-wired Voltage	115 V	220V	220V	440V
T-Slots (Table/Base)				
Number	2	2	2	2
Size	5/8 In.	5/8 In.	5/8 In.	5/8 In.
Column Diameter	4-1/2 In.	4-1/2 In.	4-1/2 In.	4-1/2 In.
Spindle				
Travel	6 In.	6 In.	6 In.	6 In.
Taper	MT-3	MT-3	MT-3	MT-3
RPM (Variable)	300-2000	300-2000	65-2000	65-2000
Quill				
Diameter	3 In.	3 In.	3 In.	3 In.
Travel	6 in.	6 in.	6 in.	6 in.
Table				
Overall	22x18-3/4 In.	22x18-3/4 In.	22x18-3/4 In.	22x18-3/4 In.
Working Surface	18-1/8x14-3/4	18-1/8x14-3/4	18-1/8x14-3/4	18-1/8x14-3/4
Travel	32-3/8 In.	32-3/8 In.	32-3/8 In.	32-3/8 In.
Base				
Overall	26x19 In.	26x19 In.	26x19 In.	26x19 In.
Working Surface	15-1/4x12-1/16	15-1/4x12-1/16	15-1/4x12-1/16	15-1/4x12-1/16
Overall Dimensions				
Length	34-1/4 In.	34-1/4 In.	36-5/8 In.	36-5/8 In.
Width	27 In.	27 In.	27 In.	27 In.
Height	77-1/4 In.	77-1/4 In.	82-1/4 In.	82-1/4 In.
Weight				
Net	715 lbs.(325 kgs) ...	715 lbs.(325 kgs)	715 lbs.(325 kgs) ...	715 lbs.(325 kgs) ...
Gross	803 lbs.(365 kgs) ...	803 lbs.(365 kgs)	792 lbs.(360 kgs) ...	792 lbs.(360 kgs) ...

1. All work shall be secured using either clamps or a vise to the drill press table. It is unsafe to use your hands to hold any workpiece being drilled.



WARNING

- Misuse of this machine can cause serious injury.
- For safety, machine must be set up, used and serviced properly.
- Read, understand and follow instructions in the Operating Instructions and Parts Manual which was shipped with your machine.

When setting up machine:

- Always avoid using machine in damp or poorly lighted work areas.
- Always be sure the machine support is securely anchored to the floor or the work bench.

When using machine:

- Always wear safety glasses with side shields (See ANSI Z87.1)
- Never wear loose clothing or jewelry.
- Never overreach—you may slip and fall.

When servicing machine:

- Always disconnect the machine from its electrical

supply while servicing.

- Always follow instructions in Operating Instructions and Parts Manual when changing accessory tools or parts.
- Never modify the machine without consulting Wilton Corporation.

You—the stationary power tool user—hold the key to safety.

Read and follow these simple rules for best results and full benefits from your machine. Used properly, Wilton's machinery is among the best in design and safety. However, any machine used improperly can be rendered inefficient and unsafe. It is absolutely mandatory that those who use our products be properly trained in how to use them correctly. They should read and understand the Operating Instructions and Parts Manual as well as all labels affixed to the machine. Failure in following all of these warnings can cause serious injuries.

Machinery general safety warnings

1. Always wear protective eye wear when operating machinery. Eye wear shall be impact resistant, protective safety glasses with side shields which comply with ANSI Z87.1 specifications. Use of eye wear which does not comply with ANSI Z87.1 specifications could result in severe injury from breakage of eye protection.
2. Wear proper apparel. No loose clothing or jewelry which can get caught in moving parts. Rubber soled footwear is recommended for best footing.
3. Do not overreach. Failure to maintain proper working position can cause you to fall into the machine or cause your clothing to get caught — pulling you into the machine.
4. Keep guards in place and in proper working order. Do not operate the machine with guards removed.
5. Avoid dangerous working environments. Do not use stationary machine tools in wet or damp locations. Keep work areas clean and well lit.
6. Avoid accidental starts by being sure the start switch is "OFF" before plugging in the machine.
7. Never leave the machine running while unattended. Machine shall be shut off whenever it is not in operation.
8. Disconnect electrical power before servicing. Whenever changing accessories or general maintenance is done on the machine, electrical power to the machine must be disconnected before work is done.
9. Maintain all machine tools with care. Follow all maintenance instructions for lubricating and the changing of accessories. No attempt shall be made to modify or have makeshift repairs done to the machine. This not only voids the warranty but also renders the machine unsafe.
10. Machinery must be anchored to the floor.
11. Secure work. Use clamps or a vise to hold work, when practical. It is safer than using your hands and it frees both hands to operate the machine.
12. Never brush away chips while the machine is in operation.
13. Keep work area clean. Cluttered areas invite accidents.
14. Remove adjusting keys and wrenches before turning machine on.
15. Use the right tool. Don't force a tool or attachment to do a job it was not designed for.
16. Use only recommended accessories and follow manufacturers instructions pertaining to them.
17. Keep hands in sight and clear of all moving parts and cutting surfaces.
18. All visitors should be kept at a safe distance from the work area. Make workshop completely safe by using padlocks, master switches, or by removing starter keys.
19. Know the tool you are using — its application, limitations, and potential hazards.

General electrical cautions

This drill press should be grounded in accordance with the National Electrical Code and local codes and ordinances. This work should be done by a qualified electrician. The saw should be grounded to protect the user from electrical shock.

Wire sizes

Caution: for circuits which are far away from the electrical service box, the wire size must be increased in order to deliver ample voltage to the motor. To minimize power losses and to prevent motor overheating and burnout, the use of wire sizes for branch circuits or electrical extension cords according to the following table is recommended.

Conductor length	AWG (American wire gauge) number	
	240 volt lines	120 volt lines
0-50 feet	No. 14	No. 14
50-100 feet	No. 14	No. 12
Over 100 feet	No. 12	No.8

Safety Instructions for Drill Presses

6

2. Drill press head and table shall be securely locked to the column before operating the drill press. This must always be checked prior to starting the machine.

3. Always use the correct tooling. Tooling shall always be maintained and properly sharpened. All tooling must be run at the proper speeds and feeds as they apply to the job. Use only recommended accessories and follow those manufacturers instructions pertaining to them. Tooling shall be not be forced in to any workpiece but fed according to the proper specifications. Failure to follow these instructions will not only ruin the tooling as well as the machine, but can cause serious injury.

4. Never brush away any chips while the machine is in operation. All clean up should be done when the machine is stopped.

5. Keep hands in sight. Do not put hands or fingers around, on, or below any rotating cutting tools. Leather safety gloves should be used when

handling any sharp objects or cutting tools. See Figure A.

6. Always wear protective eye wear when operating, servicing or adjusting machinery. Eyewear shall be impact resistant, protective safety glasses with side shields complying with ANSI Z87.1 specifications. Use of the eye wear which does not comply with ANSI Z87.1 specifications could result in severe injury from breakage of eye protection. Figure B.

7. When drilling in material which causes dust, a dust mask shall be worn. See Figure C.

8. Avoid contact with coolant, especially guarding the eyes.

9. Non-slip footwear and safety shoes are recommended. See Figure D.

10. Wear ear protectors (plugs or muffs) during extended periods of operation. See Figure E.

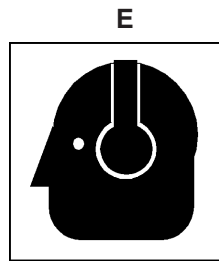
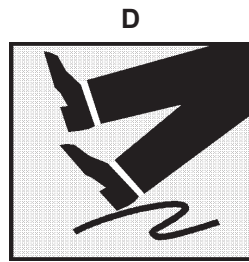
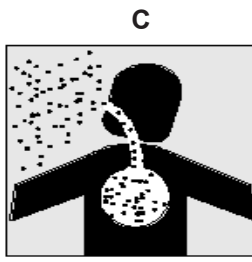
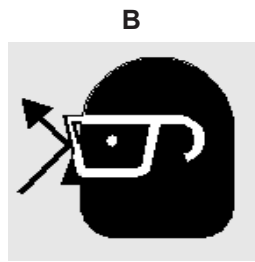
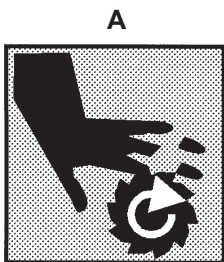

Introduction

This manual includes operating and maintenance instructions for the Wilton Model 2221VS, 2223VS, 2232AC and 2234AC Tradesman Variable Speed Drill Presses. This manual also includes parts listings and illustrations of replaceable parts.

Wilton Model 2221VS and 2223VS drill presses feature manual speed control. Models 2232AC and 2234AC have inverter speed control. This manual contains procedures for both speed control versions. The manual provides separate instructions when differences in operation and maintenance exist.

Refer to Figures 1 and 2 for key features of the drill press.

Operation and Set-up

Securing the Base

The base of the drill press has four mounting slots; two slots on both sides of the base. The drill press should be level and rest solidly on the floor. Place shims under the four mounting slots in the base as needed to level the drill press.

When securing the base to the floor, apply even torque to the fasteners to prevent distortion of the base.

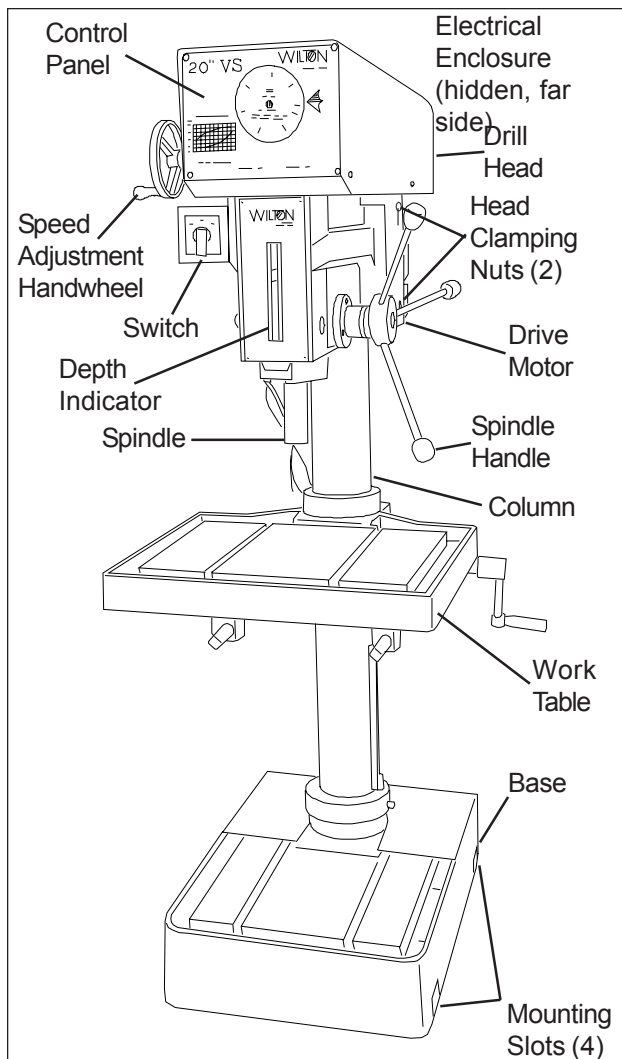

Figure 1: Drill Press Features (Manual Speed Control Model)

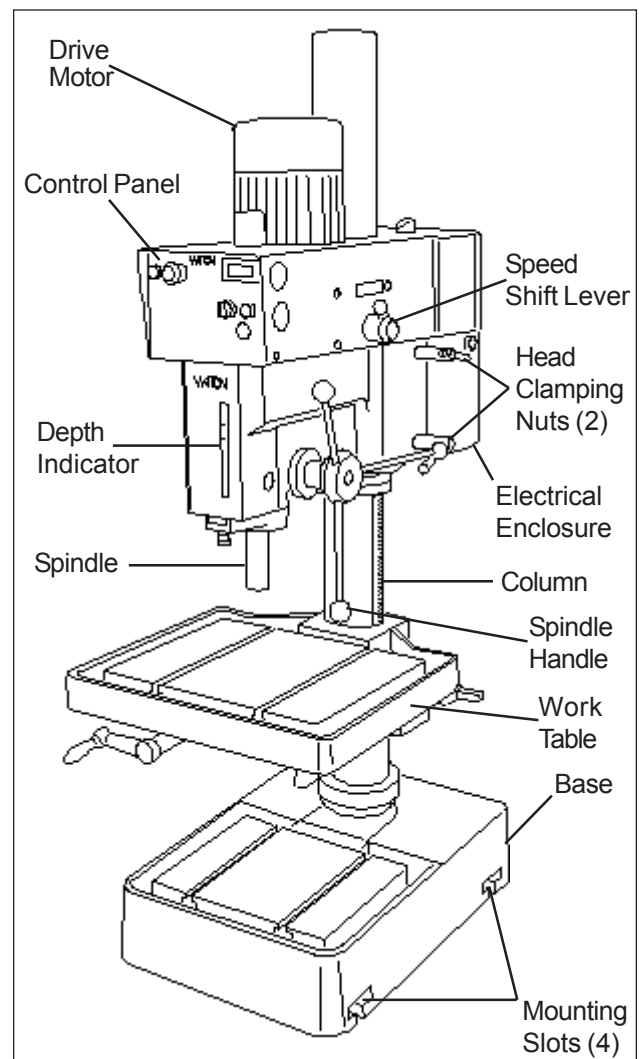

Figure 2: Drill Press Features (Inverter Speed Control Model)

Raising the Drill Head and Table

The drill press is shipped with the table and drill head supported by wooden blocks near the bottom of the column.

The head is raised to the operating position using a strap and hoist, then secured to the column by tightening the hex cap screw. The table is raised to the desired position using the crank handle.

Electrical Connection

Refer to the **Wiring Diagram** section for wiring information.

Models 2221VS (manual control) and 2232AC (inverter control) are pre-wired for 115 volts. Models 2223VS (manual control) and 2234AC (inverter control) are pre-wired for 220 volts.

Connection of electrical power should be made by a qualified electrician. Observe local electrical codes when connecting the machine.

Operating Controls

(Refer to Figures 3, 4, and 5)

Manual Speed Control -

Models 2221VS and 2223VS (See Figure 3)

Spindle Selector Switch

A three-position selector switch is provided at the left side of the drill head. It is used to select spindle rotation: reverse (REV), off (OFF), and forward (FWD).

Speed Control Hand Wheel

CAUTION: TO AVOID DAMAGE TO THE SPEED ADJUSTMENT MECHANISM, THE DRIVE MOTOR MUST BE OPERATING BEFORE ATTEMPTING TO ADJUST THE SPEED SETTING.

A speed control hand wheel is provided on the left front of the head (refer to Figure 3 for location). The handle is turned clockwise to increase spindle speed and counterclockwise to reduce speed. To set the speed, the speed control handle is turned until the pointer on the front panel is at the desired speed.

Speed Indicator

An LED spindle speed indicator is provided on the front panel. The LED indicates speeds from 300 to 2000 rpm.

8

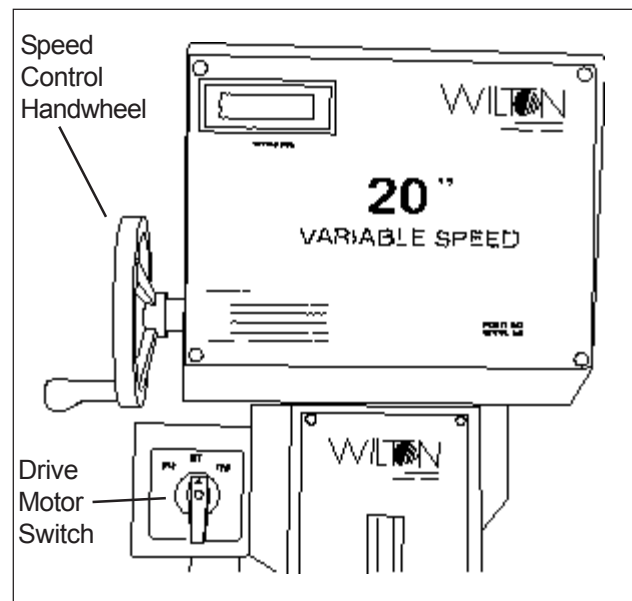

Figure 3: Control Panel (Manual Speed Control)

**Inverter Speed Control -
Models 2232AC and 2234AC** (See Figure 4)

Spindle On Pushbutton Switch

The SPINDLE ON pushbutton (green) is used to start the drive motor. To stop the motor, the pushbutton is pressed (the switch toggles on and off).

Emergency Stop Pushbutton Switch

The mushroom-shaped EMG. STOP pushbutton switch provides a quick means of stopping the drive motor.

Inverter On Indicator

The INVERTER ON light (red) indicates that the inverter is powered up.

RPM Display

The spindle speed display shows the spindle rpm selected by the spindle control knob (below).

Spindle Speed Knob

The SPINDLE SPEED knob is used to set the desired spindle speed. The speed indicator to the right of the SPINDLE SPEED knob displays the spindle speed setting.

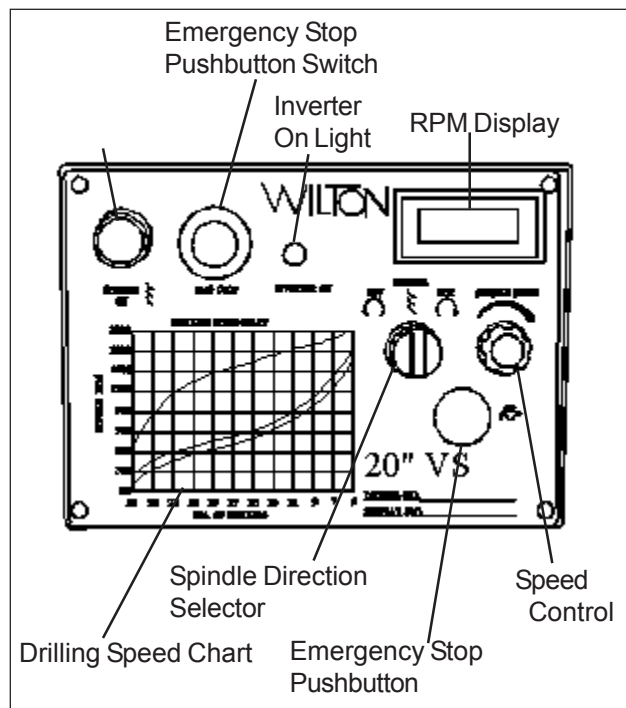

Figure 4: Control Panel (Inverter Speed Control)

Drilling Speed Chart

A DRILLING SPEED CHART is provided on the front panel. The chart can be used to select the speed required for various drill sizes (0.196 inch to 1.000 inch — 5 mm to 25 mm) and materials (steel, cast iron, aluminum, and copper). The chart defines spindle speeds from 300 to 3000 RPM.

**Depth Indicator —
All Models** (See Figure 5)

A drilling depth indicator is provided on the front of the drill head. The indicator can be set for depths up to 6.5 inches (16.5 mm). A knurled knob is provided at the front, underside of the head. Before starting the motor, set the end of the drill against the surface into which the hole is to be drilled. The indicator is zeroed out using the knurled knob. The motor is started and the hole drilled until the indicator pointer reaches the desired depth.

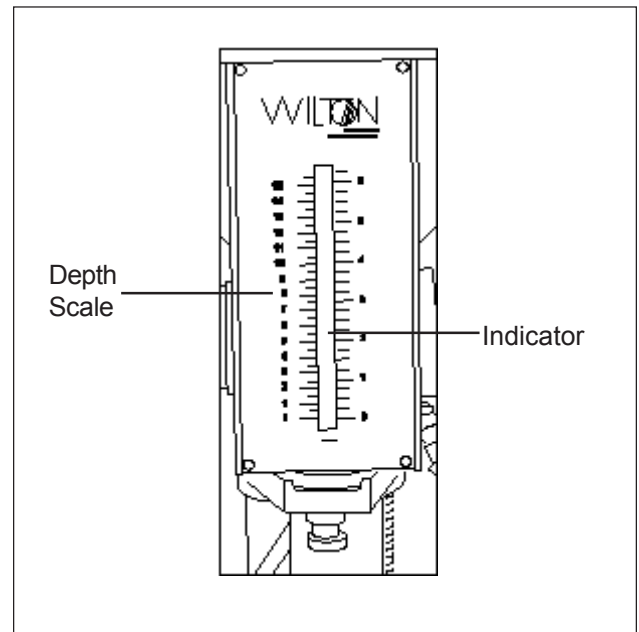

Figure 5: Depth Indicator

Maintenance

Replacement of Drive Belt

WARNING: MAKE SURE TO DISCONNECT ELECTRICAL POWER TO THE DRILL PRESS TO AVOID THE POSSIBILITY OF INADVERTENT OPERATION AND EXPOSURE TO POTENTIALLY LETHAL VOLTAGE LEVELS.

Manual Speed Control - Models 2221VS and 2223VS

1. Start drill press. Set speed control to highest speed. Stop drill press.
2. Disconnect electrical power by setting drill press circuit breaker to OFF.
3. Remove head cover.
4. Remove belt. (With speed control setting at the highest speed, the belt should be loose enough to remove.)
5. Install the replacement belt. Install the head cover.
6. Set the drill press circuit breaker ON.
7. Operate the drill press to verify correct operation.

Inverter Speed Control - Models 2232AC and 2234AC

1. Disconnect electrical power by setting drill press circuit breaker to OFF.
2. Remove pan screws from small cover (around column). Remove pan screws and eight bolts from head cover.
3. Loosen set screw and remove shift lever.
4. Remove plastic spindle cup.
5. Remove head cover. Leave small cover in place.
6. Disconnect electrical wiring from motor junction box. Remove motor from mounting plate.
7. Remove motor mounting plate.
6. Remove three screws from pulley covers (discs). Remove used belt. Install the replacement belt.
8. Install pulley covers and secure with three screws in each pulley cover.
9. Install motor mounting plate. Install motor and connect electrical wiring (refer to **Wiring Diagram** section for wiring details).
10. Install the head cover and secure with pan screws and eight bolts.
11. Secure small head cover to head cover using pan screws.
12. Set the drill press circuit breaker ON.
13. Operate the drill press to verify correct operation.

Replacement of Motor

WARNING: MAKE SURE TO DISCONNECT ELECTRICAL POWER TO THE DRILL PRESS TO AVOID THE POSSIBILITY OF INADVERTENT OPERATION AND EXPOSURE TO POTENTIALLY LETHAL VOLTAGE LEVELS.

Manual Speed Control - Models 2221VS and 2223VS

1. Remove drive belt (refer to **Replacement Of Drive Belt**).
2. Disconnect electrical wiring from motor junction box.
3. Remove nuts from mounting studs securing motor to drill head. Remove motor.
4. Remove upper and lower pulleys and related components from motor shaft.
5. Install upper and lower pulleys and related components on replacement motor shaft.
6. Install motor on mounting studs and secure with nuts.
7. Connect electrical wiring (refer to **Wiring Diagram** section for wiring details).
8. Install drive belt (refer to **Replacement Of Drive Belt**).
9. Operate drill press to verify proper operation.

Inverter Speed Control - Models 2232AC and 2234AC

Refer to **Replacement Of Drive Belt** for instructions for removal of the drive motor.

Lubrication

Following are lubrication recommendations for drill press components.

Manual Speed Control - Models 2221VS and 2223VS

1. Spindle pulley drive: Lubricate spindle splines occasionally with light grease.
2. Quill and column: Lubricate with light film of oil.
3. Lift rack: Lubricate regularly with SAE 20 oil (clean rack with kerosene before applying oil).
4. Variable drive:
 - a. Speed control fork: service oil hole with SAE 20 oil once a week.
 - b. Countershaft spindle and push rod: lubricate with SAE 20 oil occasionally.
 - c. Speed control handle cam: clean and grease with medium cup grease annually.

Inverter Speed Control - Models 2232AC and 2234AC

1. Spindle pulley drive: Lubricate spindle splines occasionally with light grease.
2. Quill and column: Lubricate with light film of oil.
3. Lift rack: Lubricate regularly with SAE 20 oil (clean rack with kerosene before applying oil).
4. Variable speed drive:
 - a. Periodically check oil level in sight gauge on (left side of head) (refer to Figure 6).
 - b. If level is below centerline of sight gauge, add oil.
 - c. To add oil, remove oil fill tube cover plate. Pull fill tube out of hole in head cover.
 - d. Add SAE 20 oil to bring oil level up to the centerline of the sight gauge.
 - e. Put end of fill tube back through hole in head cover. Install fill tube cover and secure with two screws.

Machine Adjustments

Table Adjustment (See Figure 7)

The table can be raised or lowered to accommodate the height of the workpiece. To raise or lower the table, loosen the table lock using the hand crank. Then use the hand crank to move the table to the desired height. Then lock the table in position.

Head Adjustment

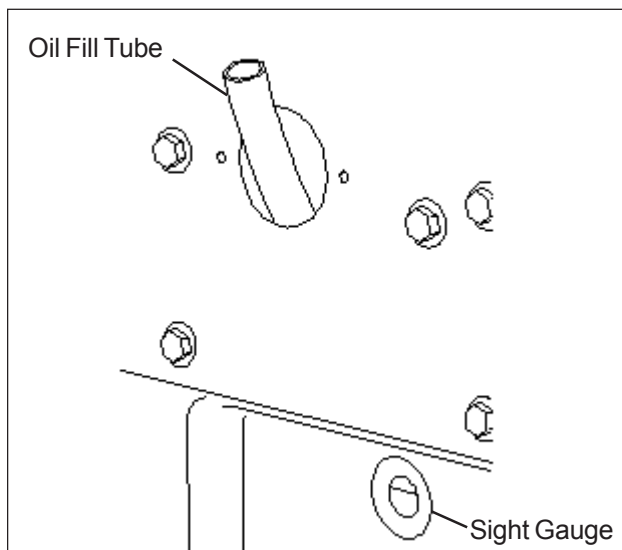

Figure 6: Oil Level Sight Gauge and Fill Tube

WARNING: CHANGE THE RADIAL POSITION OF THE DRILL HEAD ONLY IF THE DRILL PRESS BASE IS SECURED TO THE FLOOR. SWINGING THE DRILL HEAD WITHOUT THE BASE BEING SECURED TO THE FLOOR WILL CAUSE THE DRILL PRESS TO BECOME UNSTABLE AND TIP OVER RESULTING IN INJURY AND/OR DAMAGE TO THE MACHINE.

Radial Adjustment of Head (All Models)

The radial position of the drill head can be changed to accommodate the drilling of a hole that may be offset from the center of the table. Reposition the drill head as follows:

1. Loosen the two clamping hex nuts using the hex socket wrench provided with the machine.
2. The swing the drill head to the desired position.
3. Tighten the two clamping nuts.

Adjustment of Speed Pickup

(Manual Models 2221AC and 2223AC)

1. Loosen screws securing speed pickup (ref. 56-1) to bracket (ref. 56-2).
2. Adjust the speed pickup gap to approximately 1/8-inch.
3. Operate drill press to verify that speed readout is operating correctly.

(Inverter Models 2232AC and 2234AC)

1. Loosen screws securing speed pickup (ref. 68A) to bracket (ref. 70A) on drill head.
2. Adjust the speed pickup gap to approximately 1/8-inch.
3. Operate drill press to verify that speed readout is operating correctly.

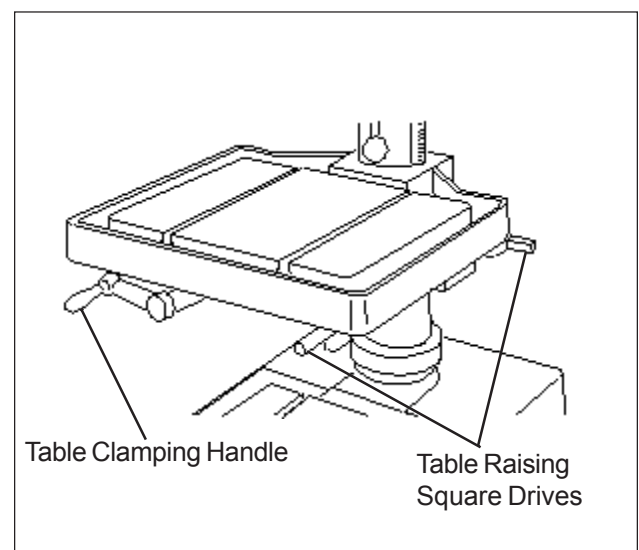

Figure 7: Table Adjustment

Operating Precautions

The following operating and safety precautions must be observed in order to avoid harm to the operator or damage to the drill press.

1. The head assembly must be locked to the column so the thrust produced by drilling will not force the head assembly up the column.
2. The work table must be locked to the column so it will not be forced down the column.
3. Before drilling, release the quill lock nut to permit free travel of the quill.
4. Be sure the belt is tightened to the proper tension.
5. **DO NOT** start to drill the workpiece until making certain the workpiece is held down securely.
6. **MAKE SURE THE DRIVE MOTOR IS RUNNING BEFORE** turning the speed control handwheel in either direction.
7. Point of operation protection is required for maximum safety. This remains the responsibility of the user/purchaser since conditions differ between jobs.
8. Make sure the drill is secured in the spindle or check before attempting to use the drill press.
9. Make sure the spindle taper is clean and free of burrs, scoring, and galling to assure maximum gripping.
10. Lock the quill in position when using and side-loaded tool.

Drilling Recommendations

Speeds for Drilling

The speed of a drill is usually measured in terms of the rate at which the outer periphery of the tool moves in relation to the work being drilled. The common term for this is Surface Feet per Minute (SFM). The relationship of SFM is expressed in the following formulas:

$$\text{SFM} = 0.26 \times \text{rpm} \times \text{Drill Diameter (in inches)}$$

$$\text{RPM} = 3.8 \times \frac{\text{SFM}}{\text{Drill diameter (in inches)}}$$

In general, the higher the speed the shorter the drill life. Operating at the low end of the speed range for a particular material will result in longer life. The most efficient speed for operating a drill depends on many variables:

1. Composition and hardness of material.
2. Depth of the hole.
3. Efficiency of the cutting fluid.
4. Type and condition of the drilling machine.
5. Desired quality of the hole.
6. Difficulty of set-up.

Feeds for Drilling

The feed of a drill is governed by the size of the tool and the material drilled. Because the feed rate partially determines the rate of production and also is a factor in tool life, it should be chosen carefully for each job. In general, the most effective feeds will be found in the following ranges:

Diameter of Drill (inches)	Feed per Revolution (inches)
Under 1/8	0.001 to 0.002
1/8 to 1/4	0.002 to 0.004
1/4 to 1/2	0.004 to 0.007
1/2 to 5/8	0.007 to 0.015

Indication of Extreme Speeds and Feeds

A drill that splits up the web is evidence of too much feed or insufficient tip clearance at the center as a result of improper grinding. The rapid wearing away of the extreme outer corners of the cutting edges indicates that the speed is too high. A drill chipping or braking out at the cutting edges indicates that either the feed is too heavy or the drill has been ground with too much tip clearance.

Speeds for High Speed Steel Drills

Material	Speed In SFPM
Alloy Steel — 300 to 400 Brinell	20 - 30
Stainless Steel	30 - 40
Automotive Steel Forgings	40 - 50
Tool Steel, 1.2C	50 - 60
Steel, .4C to .5C	70 - 80
Mild Machinery Steel, .2C to .3C	80 - 110
Hard Chilled Cast Iron	30 - 40
Medium Hard Cast Iron	70 - 100
Soft Cast Iron	100 - 150
Malleable Iron	80 - 90
High Nickel Steel or Monel	40 - 50
High Tensile Bronze	70 - 150
Ordinary Brass and Bronze	200 - 300
Aluminum and its Alloys	200 - 300
Magnesium and its Alloys	250 - 400
Slate, Marble, and Stone	15 - 25
Plastics and similar material (Bakelite)	100 - 150
Wood	300 - 400
Titanium Alloys	10 - 25
Titanium Alloy Sheet	50 - 60

In cases where carbon steel drills are applicable, the drill should be run at speeds of from 40 to 50 percent of those given above.

Wiring Diagram - Models 2221 & 2223

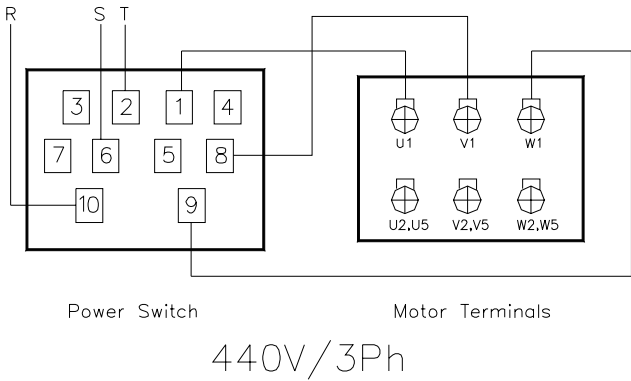
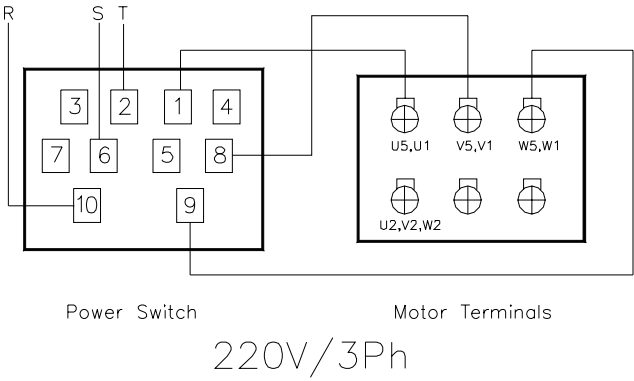
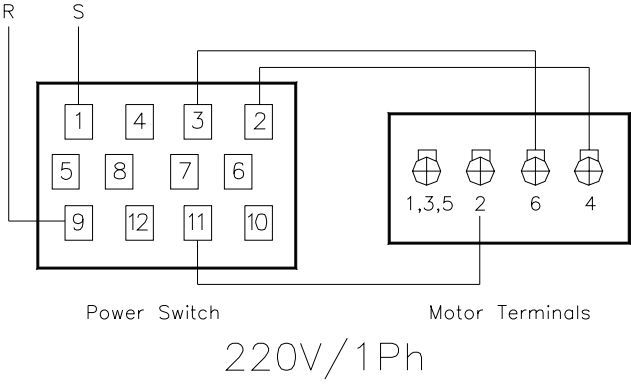
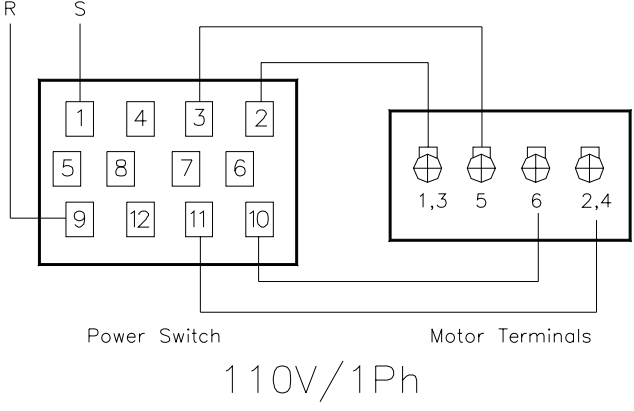

Wiring Diagram - Models 2232AC & 2234AC

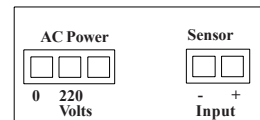
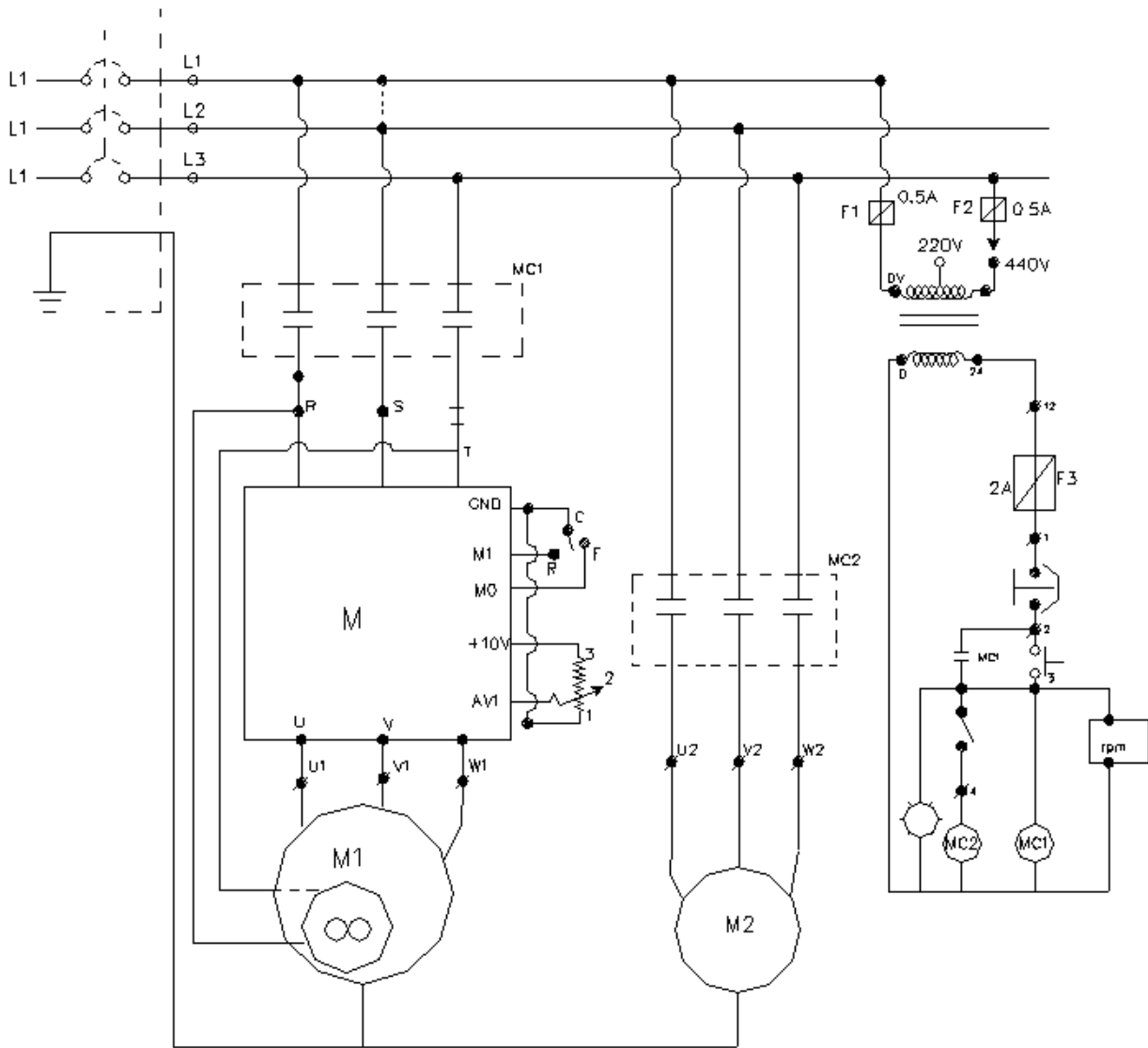

**3 Phase 220/440
LED Display Connection**

Troubleshooting

Problem	Possible Cause	Remedy
Spindle does not turn.	<ol style="list-style-type: none"> 1. Motor overload protector tripped. 2. Circuit breaker tripped. 3. Branch circuit breaker tripped or fuse blown. 4. Open wire in switch circuit. 5. Defective switch. 6. Broken drive belt. 	<ol style="list-style-type: none"> 1. Press motor overload reset button. 2. Reset circuit breaker. 3. Reset branch circuit breaker/replace fuse. 4. Repair open circuit. 5. Replace switch. 6. Replace drive belt.
Spindle noisy.	<ol style="list-style-type: none"> 1. Damaged spindle bearings. 2. Worn spline. 	<ol style="list-style-type: none"> 1. Replace bearings. 2. Replace spline.
Drill stalls.	<ol style="list-style-type: none"> 1. Worn drive belt. 2. Excessive feed rate for size of drill and material being drilled. No cutting fluid or improper cutting fluid. 	<ol style="list-style-type: none"> 1. Check condition of belt. Replace if glazed or slipping on pulleys. 2. Reduce feed pressure or use cutting fluid. Use correct cutting fluid.
Poorly drilled holes.	<ol style="list-style-type: none"> 1. Drill dull. 2. Lack of rigidity in hold-down method. 3. Speed too fast for material and drill size. 4. Feed too fast for material and drill size. 5. No or improper cutting fluid or coolant being used. 6. Improperly ground drill bit. 	<ol style="list-style-type: none"> 1. Sharpen drill. 2. Check that all T-slot hold-downs are tight and that table-lock and drill head bolts are tight. 3. Check spindle speed recommendations. Reduce speed if necessary. 4. Reduce feed rate. 5. Use cutting fluid, or change to proper fluid or coolant for material being drilled. 6. Check for proper angles and reliefs. Regrind to proper geometry.
Motor overheating	<ol style="list-style-type: none"> 1. Electrical circuit fault. 2. Oversize drill. 3. Excessive feed. 4. No cutting fluid, or wrong fluid. 	<ol style="list-style-type: none"> 1. Check current draw in circuit. Make sure current draw is the same as rating on motor plate. 2. Reduce drill size. 3. Reduce feed rate. 4. Use correct cutting fluid for the material and drill.
Table can not be raised.	<ol style="list-style-type: none"> 1. Lack of lubrication. 	<ol style="list-style-type: none"> 1. Lubricate.
No speed readout.	<ol style="list-style-type: none"> 1. Speed pickup out of adjustment or failed. 	<ol style="list-style-type: none"> 1. Adjust gap between speed pickup and post spindle pulley. If there is no readout on the LED speed indicator after adjusting the gap, replace the speed pickup.

Optional Equipment Coolant System Installation

1. Remove the large reservoir cover plate from the machine base. Tap 1/4-20 threads in the 4 pilot holes. Install the cover plate back onto the machine base.

2. Insert the pump into the opening, utilize the screws from the small round cover plate to fasten the pump to the base.

3. Position the power switch and valve bracket on the spindle casting. Mark mounting hole locations and drill holes. (Refer to **Figure 8**).

Note: Mount components near the lower edge of the spindle casting. Do not mount components above the line shown in Figure 9.

5. Install the 3/8-inch hose barb to the coolant pump. If needed apply a light coat of pipe sealant or Teflon tape to the threads to prevent leakage.

6. Mount the flow valve to the bracket, connect the supply hose to the pump and valve, use hose clamps at the ends.

7. Install the flexible nozzle to the flow valve.

8. Install the 1/2-inch hose barb to the worktable, seal threads if needed. Connect the return hose.

9. Connect the power cord to a suitable source and ground (refer to **General Electrical Cautions**).

10. Fill the reservoir with appropriate machining coolant.

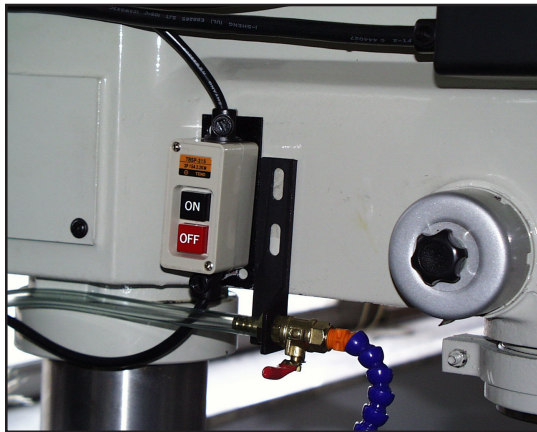
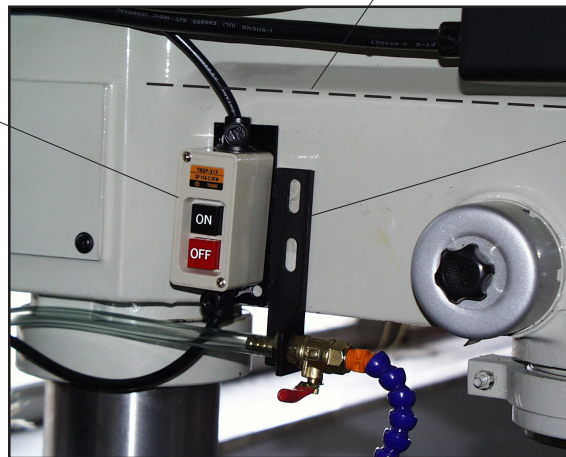

Figure: 8 Suggested installation

Do not mount components
above this line.



Power switch - mounting
plate flush with bottom
edge of spindle casting.

Flow valve
mounting bracket.

Figure 9: Installation Detail

Replacement Parts

This section provides exploded view illustrations that show the replacement parts for Wilton Model 2221VS, 2223VS, 2232AC, and 2234AC 20-Inch Tradesman Drill Presses. Also provided are parts listings that provide part number, description, and quantity. The item numbers shown on the illustration relate to the item number in the facing page of the parts listing.

Separate exploded views and parts listings are provided for the drill heads for manual speed control drill presses (Models 2221VS and 2223VS) and the inverter speed control drill presses (Models 2232AC and 2234AC). The exploded view and parts listing for the drill press spindle components, and the table, base, and column apply to all models.

Order replacement parts from:

WMH TOOL GROUP

2420 Vantage Drive
Elgin, IL 60123
Phone: 800-274-6848

Identify the replacement part by the part number shown in the parts listing. Be sure to include the model number and serial number of your machine when ordering replacement parts to assure that you will receive the correct part.

Exploded View — Drill Head — Manual Speed Control (Models 2221VS and 2223VS)

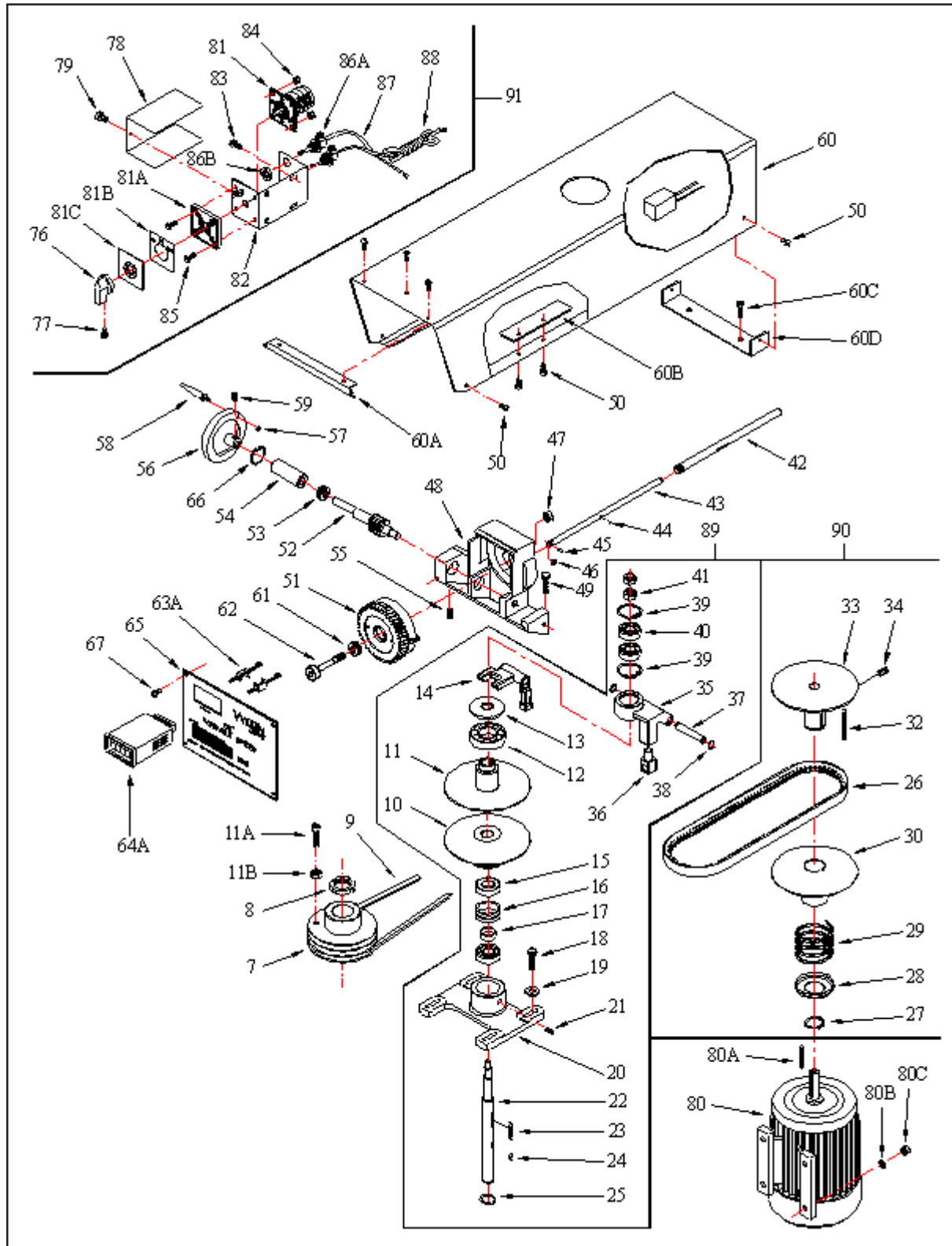

Parts Listing — Drill Head — Manual Speed Control

(Models 2221VS and 2223VS)

Item No.	Part Number	Description	Qty	Item No.	Part Number	Description	Qty
7	5510077	Pulley, Spindle Step	1	58	5510126	Grip, Hand	1
8	5510078	Nut, Spindle	1	59	5510129	Screw, Set	1
9	5510079	V-Belt	1	60	5513678	Assy., Pulley Cover (incl 60A,60B,60C,60D)	1
10	5510080	Pulley, Spindle, VS, Lower	1	60A	5513679	Bracket, Nameplate	1
11	5510081	Pulley, Spindle, VS, Upper	1	60B	5513680	Plate, Cover	1
11A	5513673	Screw, Cap	1	60C	5513681	Screw, Cap	2
11B	5513674	Nut, Hex	4	60D	5513682	Bracket, Plate	1
12	5510082	Bearing, Ball	1	61	5510131	Bearing, Thrust	1
13	5510083	Cover, Bearing	1	62	5510132	Shaft	1
14	5510084	Lever, Speed Change	1	63A	5513683	Screw, Cap	2
15	5510085	Bearing, Ball	2	64A		LED Display	
16	5510086	Bushing	1		5513519	115/230 LED Display	
17	5510087	Bushing	1		5513736	220/440 LED Display	
18	5510088	Bolt, Hex	4	65	5513690	Plate, Face	1
19	5510089	Washer	4	66	5513685	C-Ring (Hole)	1
20	5510090	Housing, Bearing	1	67	5510137	Screw, Round Head	4
21	5510091	Screw, Set	1	76	5511848	Knob	1
22	5510092	Shaft, Spindle Mid	1	77	5514634	Set Screw (M3x8)	1
23	5510093	Key	1	78	5511849	Cover	1
24	5510094	Key	1	79	5513354	Screw	2
25	5510095	C-Ring (Shaft)	1	80	5519925	2221VS Motor 1ph 120/230	1
26	5510096	Belt, Variable Speed	1			GT Serial# 209139	
27	5510097	C-Ring (Shaft)	2		5519926	2223VS Motor 3ph 230/460	1
28	5510098	Cover, Spring	1			GT Serial# 209139	
29	5510099	Spring			5510344	Motor 2hp 1ph 115/220V	1
30	5510100	Pulley, Motor, VS, Lower	1			LT Serial# 209139	
32	5510102	Key	1		5510345	Motor 2hp 3ph 220/440V	1
33	5510103	Pulley, Motor, VS, Upper	1			LT Serial# 209139	
34	5510104	Screw, Set	1	80A	5517320	Key, Square	1
35	5510105	Bracket, Speed Change	1	80B	5517321	Washer, Flat	4
36	5510106	Link	1	80C	5517322	Nut, Hex	4
37	5510107	Shaft	1	81		Switch, Fwd/Rev	1
38	5510108	C-Ring (Shaft)	1		5517323	1 Phase	
39	5510109	C-Ring (Hole)	1		5517331	3 Phase	
40	5510110	Bearing, Ball	2	81A	5517324	Plate, Switch	1
41	5510111	Nut	2	81B	5517325	Label	1
42	5512114	Sleeve, Control Rod	1	81C	5517326	Cover, Label	1
43	5512115	Rod, Control	1	82	5513356	Box, Switch	1
44	5510114	Pin Spring	1	83	5513357	Screw	2
45	5510115	Pin	1	84	5513358	Nut, Hex	4
46	5510116	Roller	1	85	5513359	Screw	4
47	5510117	Nut, Hex	1	86A	5517327	Strain Relief	2
48	5512116	Housing	1	86B	5517328	Nut, Hex	2
49	5513675	Screw, Cap (M8x35)	2	87	5517329	Cord, Connection	1
50	5513676	Screw, Pan Head	6	88	5517330	Cord, Power	1
51	5510121	Gear, Helix	1	89	5513935	Assy., VS Spindle Pulley	1
52	5510122	Gear, Worm	1	90	5513934	Assy., VS Motor Pulley	1
53	5510123	Bearing, Thrust	1	91		Assy., Switch (includes items 76-79,81-85)	1
54	5510124	Bushing	1		5513355	1 Phase	
55	5513677	Set Screw	1		5514716	3 Phase	
56	5510126	Wheel, Hand (includes #58)	1				
57	5510127	Ring, Retaining	1				

Exploded View — Drill Head — Inverter Speed Control (Models 2232AC and 2234AC)

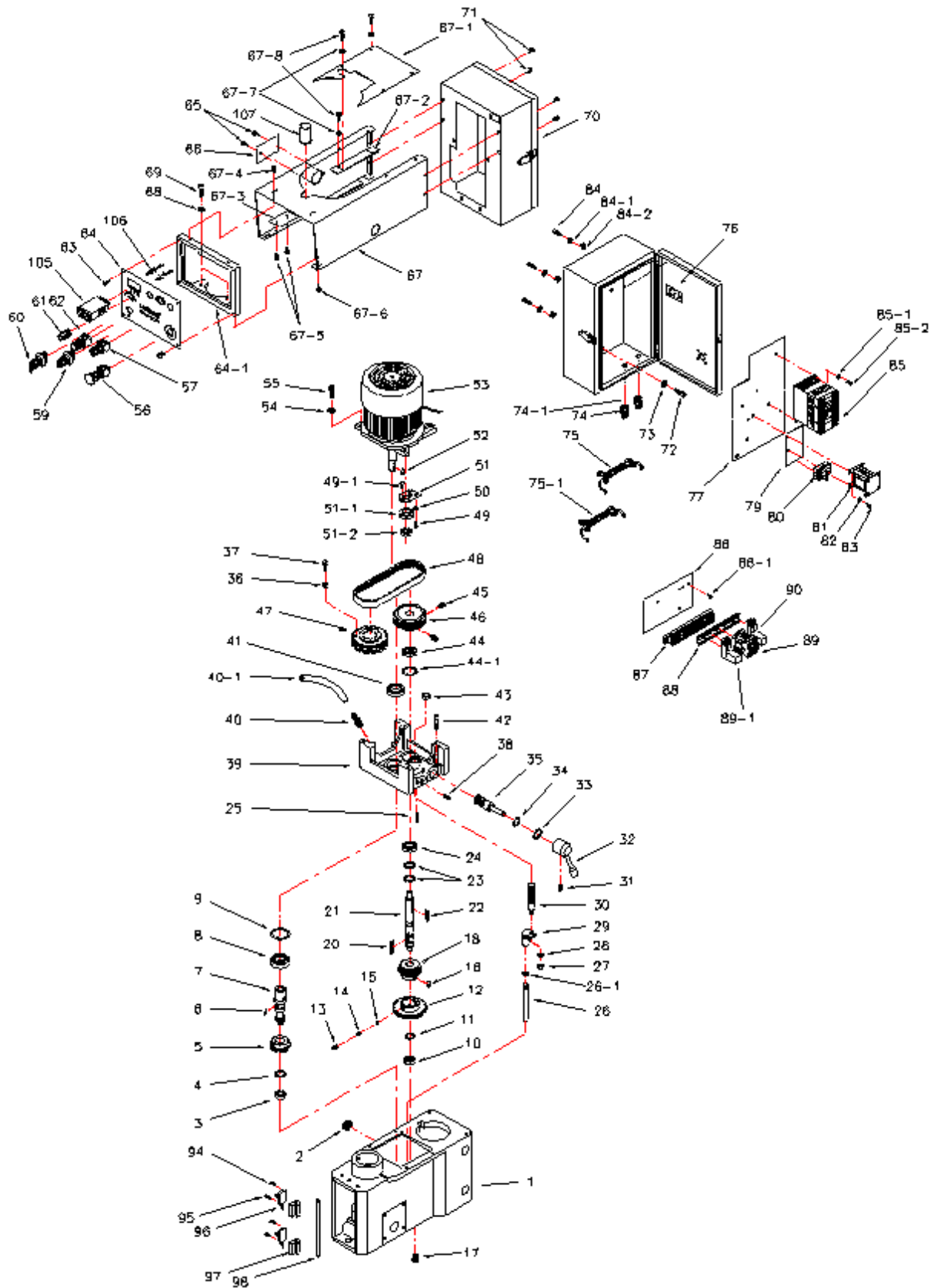

Parts Listing — Drill Head — Inverter Speed Control (Models 2232AC and 2234AC)

Item No.	Part Number	Description	Qty	Item No.	Part Number	Description	Qty
1	5517332	Casting, Head	1	51-1	5517347	Housing, Bearing	1
2	5510142	Window, Oil	1	51-2	5517348	Bearing, Ball, 6002ZZ	1
3	5510143	Bearing, Ball	1	52	5510192	Key	1
4	5510144	Ring, Retaining	1	53		Motor, 2hp, 3ph	1
5	5510145	Gear (32T)	1		5517349	220V	
6	5510146	Key	1		5517350	440V	
7	5510147	Shaft, Drive (13T)	1	54	5510194	Washer	4
8	5510148	Bearing, Ball	1	55	5510195	Screw	4
9	5510149	Ring, Retaining	1	56	5510204	Switch, E-stop	1
10	5510150	Bearing, Ball	1	56-1	5510197	Proximity Switch, Speed	1
11	5510151	Ring, Retaining	1	56-2	5510198	Bracket, Proximity Switch	1
12	5510153	Gear (55T)	1	57	5510201	Light, Indicator	1
13	5510152	Screw, Set	1	59	5510199	Switch, Pump Selector	1
14	5510155	Spring	1	60	5510200	Switch, Forward/Reverse	1
15	5510154	Ball, Steel	1	61	5510196	Potentiometer, Speed Control	1
16	5510159	Key	1	62	5510202	Switch, Pushbutton, Green	1
17	5517333	Plug, Drain, 3/8 NPT	1	63	5510206	Screw	4
18	5510158	Gear (18T)	1	64	5517351	Panel, Control	1
20	5510160	Key	1	64-1	5517352	Bracket, Plate	1
21	5510161	Shaft, Mid	1	65	5510209	Screw, Pan Head	2
22	5510162	Key	1	66	5510210	Cover, Oil Filler	1
23	5510163	Ring, Retaining	2	67	5517353	Cover, Pulley	1
24	5510164	Bearing, Ball	1	67-1	5517354	Plate, Top	1
25	5510165	Pin 1	1	67-2	5510213	Plate, Fixed	1
26	5510166	Bar	1	67-3	5517355	Plate, Fixed	1
26-1	5517334	Ring	1	67-4	5510215	Screw, Pan Head	2
27	5510167	Nut, Hex	1	67-5	5517356	Screw	2
28	5510168	Washer, Spring	1	67-6	5517357	Screw	2
29	5510169	Block, Speed Change	1	67-7	5517358	Washer	6
30	5510170	Bar, Gear	1	67-8	5510214	Screw, Pan Head	4
31	5510171	Screw, Set	1	68	5510216	Washer, Spring	2
32	5517335	Lever, Speed	1	69	5510217	Screw	2
33	5517336	Ring, Retaining	1	70	5517359	Enclosure (w/door & latch)	1
34	5510173	Seal, Oil	1	71	5510219	Screw	4
35	5510177	Shaft, Gear (18T)	1	72	5510220	Bolt	4
36	5517337	Nut, Hex	1	73	5517360	Washer	4
37	5517338	Screw, Cap	1	74	5510222	Relief, Cable	1
38	5510178	Screw, Set	1	74-1	5517361	Relief, Cable	1
39	5517339	Cover (Top), Gearbox	1	75	5510223	Cable, Electric	1
40	5510180	Fitting, Fill, Oil	1	75-1	5517362	Cable, Electric	1
40-1	5517340	Tube, Fill	1	76	5510224	Cover, Window	1
41	5510181	Seal, Oil	1	77	5517363	Panel, Component Mounting	1
42	5510182	Bolt	1	79	5510227	Board, Insulation	1
43	5510183	Seal, Oil	1	80	5510228	Fuse Block	1
44	5510184	Seal, Oil	1	81	5510229	Transformer	1
44-1	5517341	Ring, Retaining	1	82	5517364	Washer	4
45	5510185	Screw, Set	1	83	5517365	Screw, Pan Head	4
46	5510186	Pulley, Drive	1	84	5517366	Screw, Cap	4
47	5517342	Pulley, Spindle, 48T	1	84-1	5517367	Washer, Lock	4
48	5517343	Belt, 720x8	1	84-2	5517368	Nut, Hex	4
49	5510189	Bolt, Hex, M6x30	2	85		Inverter, Delta, M-type	1
49-1	5517344	Screw, Flat Head, M5x10	2		5510233	220V, 3ph	
50	5517345	Washer, Flat, M6	2		5512670	440V, 3ph	
51	5517346	Bracket	1				

Parts Listing — Drill Head — Inverter Speed Control (Models 2232AC and 2234AC)

Item No.	Part Number	Description	Qty
85-1	5517371	Washer, Flat	4
85-2	5517372	Screw	4
86	5517373	Sub-Panel	1
86-1	5517374	Screw	4
87	5510235	Terminal Block	1
88	5517375	Rail, Mounting	1
89	5510237	Contactor	1
89-1	5510238	Relay	1
90	5510240	Relay	1
94	5510242	Screw	2
95	5510243	Screw	2
96	5510244	Microswitch	2
97	5510245	Bracket, Microswitch	2
98	5510246	Rod, Microswitch Support	1
99		Electrical Enclosure Complete	1
	5514648	220V, 3Ph	
	5514649	440V 3Ph	
105		LED Display	1
	5513519	115/220 LED Display	
	5513736	220/440 LED Display	
106	5513683	Screw, Cap	2
107	5515285	Cap, Spindle	1

Exploded View — Spindle Components (All Models)

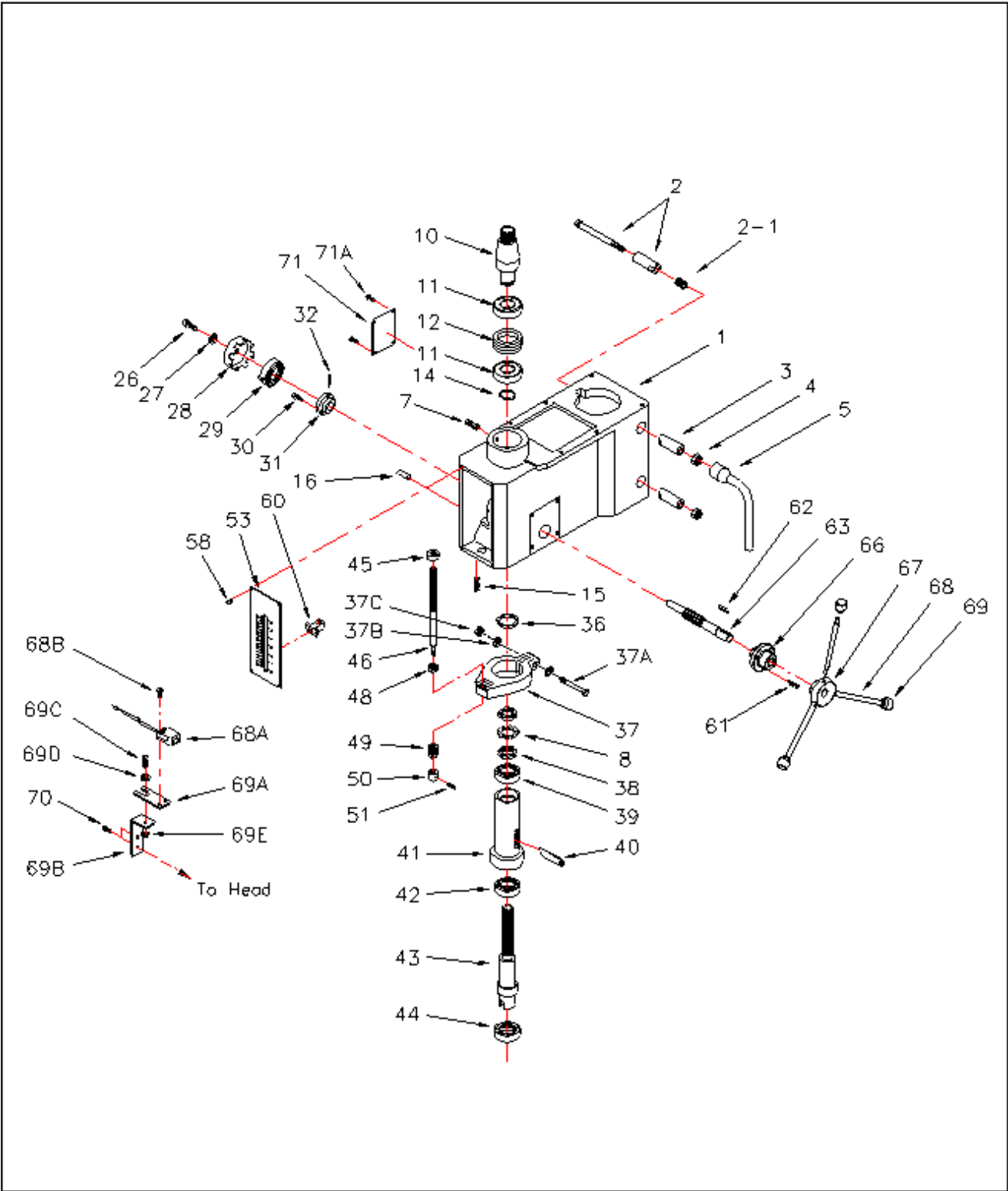

Parts Listing — Spindle Components (All Models)

Item No.	Part Number	Description	Qty
1	5517332	Casting, Head	1
2	5517376	Bolt, Hex, Shoulder	2
2-1	5517377	Spring	2
3	5517378	Rod, Cam Lock	2
4	5510250	Nut, Hex	2
5	5510251	Wrench, Hex Head	1
7	5510252	Screw, Set	1
8	5517379	Washer, External Tooth	1
10	5510253	Spindle	1
11	5510254	Bearing, Ball	2
12	5510255	Spacer	1
14	5510256	C-Ring	1
15	5510258	Screw, Set	1
16	5510259	Pin, Roll	1
26	5510261	Screw, Socket Head	1
27	5510262	Washer	1
28	5510263	Container, (includes #29)	1
29	5510263	Spring, Return	1
30	5510265	Screw, Socket Head	3
31	5510266	Seat, Spring	1
32	5510267	Pin, Spring	1
36	5513770	Washer, Rubber	1
37	5513771	Band, Quill	1
37A	5517380	Bolt, Hex, Shoulder	1
37B	5517381	Washer, Flat	2
37C	5517382	Nut, Hex	1
38	5513772	Nut, Lock	2
39	5513773	Bearing, Ball	1
40	5513774	Pin, Drift	1
41	5510268	Quill	1
42	5510269	Bearing, Ball	1
43	5510270	Spindle	1
44	5510271	Seal, Oil	1
45	5510272	Nut	1
46	5510273	Rod, Depth	1
48	5510274	Nut	1
49	5510275	Nut	1
50	5510276	Retainer	1
51	5510277	Pin, Spring	1
53	5510278	Scale, Depth	1
58	5510279	Screw, Round Head Cap	4
60	5510280	Key	1
61	5510281	Screw, Socket Head	3
62	5510282	Key	1
63	5510283	Shaft, Feed	1
66	5510284	Seat, Feed Shaft	1

Item No.	Part Number	Description	Qty
67	5510285	Hub	1
68	5510286	Spoke	3
68A	5513515	Pickup, Magnetic	1
68B	5513687	Screw, Pan Head	2
69	5510287	Knob	3
69A	5517383	Plate, Adjustable	1
69B	5517384	Bracket, Mag. Pickup	1
69C	5513689	Screw, Cap	1
69D	5517385	Washer, Flat	1
69E	5517386	Nut, Hex	1
70	5517387	Screw	2
71	5511849	Cover	1
72	5513354	Screw	4

Exploded View - Table and Base (All Models)

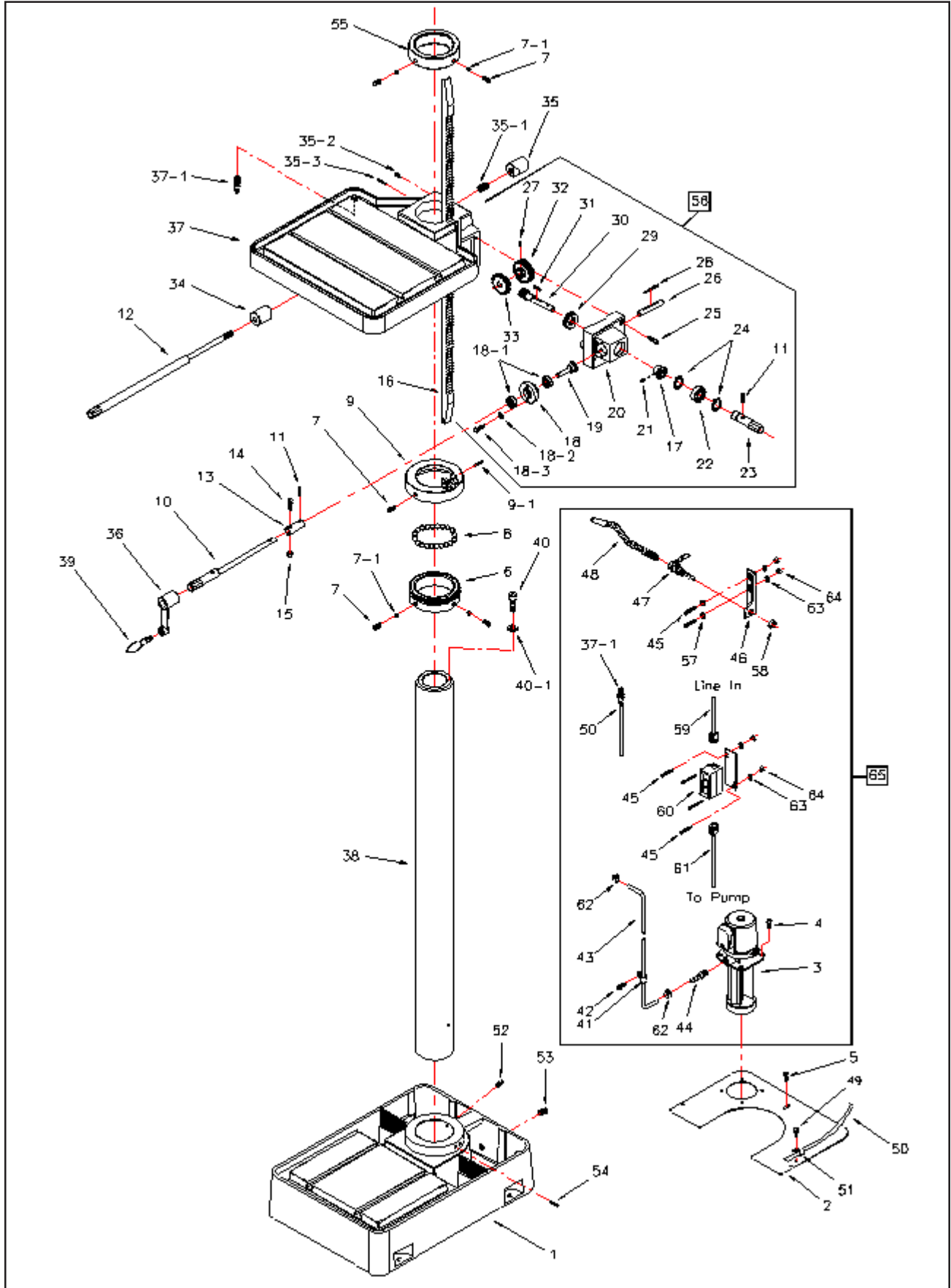

Parts List - Table and Base (All Models)

Item No.	Part Number	Description	Qty
1	5510288	Base	1
2	5510289	Plate, Coolant Cover	1
3	5510456	Pump, Coolant, 115V, 1P	1
	5512103	Pump, Coolant, 220/440V 3P	1
4	5510291	Bolt, Hex	4
5	5517388	Screw, Pan Head	3
6	5510293	Seat, Ball	1
7	5510294	Screw, Set	4
7-1	5517389	Block, Brass	4
8	5510295	Bearing, Ball	1
9	5510296	Ring, Lock	1
9-1	5517390	Pin	1
10	5516859	Shaft, Table Raiser	1
11	5510298	Pin, Spring	4
12	5516858	Shaft, Table Clamp	1
13	5516860	Coupling, Table Raiser	1
14	5510300	Screw, Socket Head	1
15	5510301	Nut	1
16	5510302	Rack	1
17	5514663	Gear, Bevel, Large	1
18	5517391	Housing, Bearing	1
18-1	5517392	Bearing, Ball, 6202ZZ	2
18-2	5517393	Washer	2
18-3	5510303	Screw, Cap	2
19	5510304	Gear, Bevel, Small	2
20	5510305	Bracket Cover	1
21	5510306	C-Ring	1
22	5510307	Bearing, Ball	1
23	5510308	Shaft	1
24	5510309	C-Ring	2
25	5510310	Screw, Socket Head	4
26	5510311	Shaft	1
27	5517395	Screw, Set	1
28	5510313	Key	1
29	5510314	Bearing	1
30	5510315	Worm, Table Raise	1
31	5510316	Key	1
32	5510317	Gear, Worm	1
33	5510318	Gear	1
34	5510319	Lock, Cam, Front	1
35	5510320	Lock, Cam, Rear	1
35-1	5517396	Spring	1
35-2	5517397	Screw, Cap, M6x25	1
35-3	5517398	Pin, 5x25	2
36	5510321	Crank, Table Raise	2
37	5510322	Table	1
37-1	5517399	Barb, Hose, 1/2" (return)	1
38	5510323	Column	1
39	5510324	Handle, Table Raise	1
40	5510325	Screw, Hex Head	1
40-1	5510334	Washer	1

Item No.	Part Number	Description	Qty
41	5510326	Clamp	1
42	5510327	Screw, Pan Head	1
43	5510328	Hose, Vinyl, Clear, 3/8"	1
44	5510329	Barb, Hose, 3/8" (supply)	1
45	5512112	SHCS, #10-32 x 1"	4
46	5510331	Bracket, Mounting	1
47	5510332	Valve	1
48	5510333	Nozzle, Flexible	1
49	5517400	Screw, Pan Head	1
50	5517401	Hose, Vinyl, Clear, 1/2"	1
51	5517402	Clamp, Hose	1
52	5517403	Screw, Set, 1/2 x 1	2
53	5517404	Plug, Drain, 3/8 NPT	1
54	5517405	Pin, Spring, 4x50	1
55	5517406	Collar, Rack	1
56	5513932	Assembly, Table Raiser	1
57	9057451	Washer, Flat, #10	2
58	5517488	Nut, Hex, 1/2"	1
59	5517489	Cord, Power	1
60	5517490	Assy., Switch	1
61		Cord, Pump	1
	5517491	1 Phase	
	5517492	3 Phase	
62	5517493	Clamp, Hose, Rad. Type	2
63	9058341	Washer, Lock, #10	4
64	5517628	Nut, Hex, #10-32	4
65		Coolant System Complete	1
	5512104	1/8 HP, 115/220V, 1 Phase	
	5508071	1/8 HP, 220/440V, 3 Phase	



WMH TOOL GROUP

2420 Vantage Drive

Elgin, IL 60123

Phone: 800-274-6848